

# SYSTEM 40<sup>®</sup> MOTORISED ROLLER SYSTEM LITHIUM RE-CHARGEABLE BATTERY 1100 SERIES

Max width: 2.5m  
Max drop: up to 6m (fabric dependant)  
Max area: up to 15m<sup>2</sup> (fabric dependant)

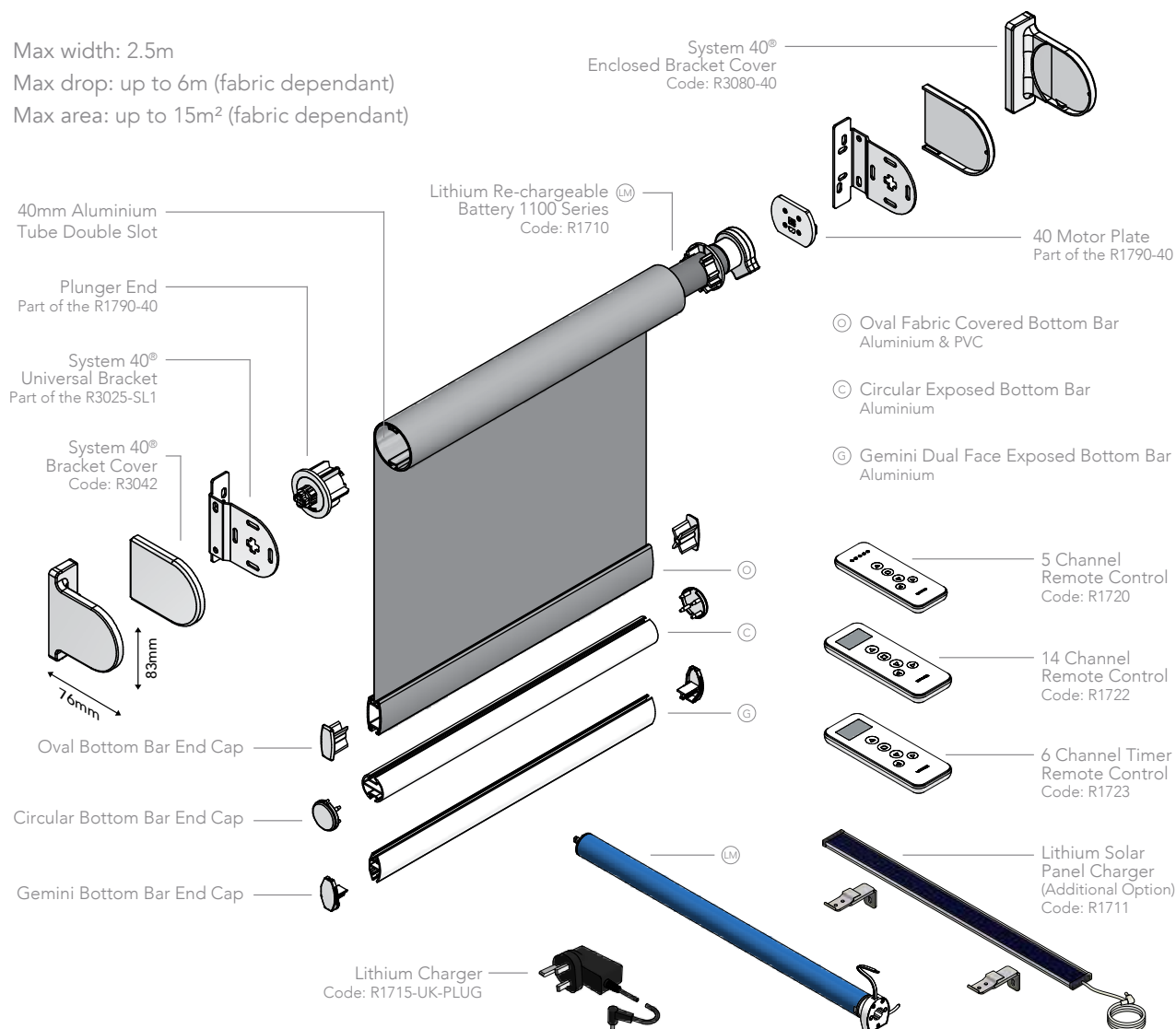

- Operate blinds effortlessly and economically with the Louvolite One Touch<sup>®</sup> Lithium re-chargeable 1100 Series.
- Manufactured using high quality engineering grade polymer.
- Easy and quick installation, no wiring needed.
- Child safe by design. Limits to stop blind at highest, mid and lowest point.
- Conveniently operate multiple blinds from anywhere in the room with the 5 channel remote, 14 channel remote or the 6 channel timer remote.
- Can be operated with the Louvolite Smart Home Hub (R1764-UK). Using wifi any One Touch blinds can be operated either through the Louvolite app on a phone or tablet anywhere in the world or by voice command with Amazon Alexa, Dot, Echo and Google Pixel. For blinds up to 3kgs in weight.
- Charge your Lithium motor with the 8.4v charger (4m cable) or with the solar panel charger (1.4m cable) which trickle charges the motor from daylight.
- For blinds up to 5kgs use the Hard Wired AC Motor 1500 (R1725) or up to 12kgs use 6000 Series (1740).
- Colours available: 40mm motor set: white, beige, black and anthracite grey; 40mm Hybrid closed cassette motor set: white and black; Remotes: white

# HARDWARE SPECIFICATION

## Motorised Roller System

Our motorised roller blinds are manufactured using the specifically designed grooved aluminium tubing. The specified fabrics are formed and held into the tube with locking tape.

The brackets are made from mild steel, zinc plated and powder coated, suitable for top, face or side fixing.

A sprung plunger end mechanism is positioned at the opposite end to the motor plate, providing a more secure fit of the blind.

## Performance

To ensure a positive performance, all Louvolite components are designed and manufactured in the UK using prime quality plastic materials.

10 year life cycle testing is done to ensure long lasting performance.

## Operation

Using motorised operation, all blinds must be compliant with the child safety elements of BS EN13120.

## Bottom Bar

Oval, made of aluminium or pvc, can be single or double wrapped in fabric or left exposed, while circular and the dual face Gemini, made of aluminium, only have the fabric formed and locked into the top part to leave the bar exposed. All fabric is formed and held into place with locking tape. The dual face Gemini bar, smooth on one side and angular on the other, improves the ease of manufacture and use of thicker laminate fabrics.

## Maintenance

All of the roller blind system components are manufactured using aluminium, treated steel and plastic. They do not present any corrosion problems in normal environments. The system has been designed for a smooth operation, together with a rigidity to prolong the window blind's working life. Manufacturing size restrictions are included in this specification brochure.

# ADDITIONAL OPTIONS - CASSETTES

System 32/40® Open Cassette  
- 40mm fascia depth. Code: RM2106  
white, beige, black satin, chrome, bronze & anthracite grey

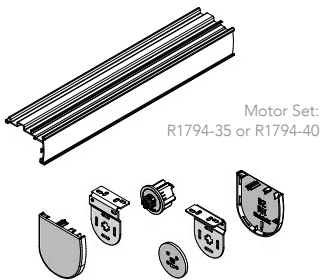

Motor Set:  
R1794-35 or R1794-40

Bracket Covers: RM2134  
white, beige, black satin, chrome, bronze, grey & anthracite grey

System 32/40® Full Fascia Cassette  
- 70mm fascia depth. Code: RM2108  
white, black & anthracite grey

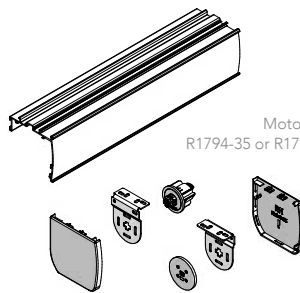

Motor Set:  
R1794-35 or R1794-40

Bracket Covers: RM2138  
white, black & anthracite grey

System 32/40® Hybrid Closed Cassette.  
Fixing extrusion code: R3360  
Curved profile code: R3362  
white, black & anthracite grey

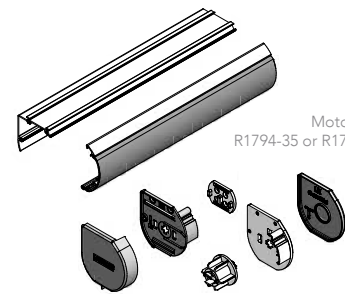

Motor Set:  
R1794-35 or R1794-40

## SYSTEMS MAX BLIND SIZE

	FABRIC GROUP	BLIND WIDTH (m) FOR BLIND DROP (m)					MAX HOLDING WEIGHT
		0.5	1.0	1.5	2.0	2.5	
35°	up to 200g/m sq	3.0	3.0	3.0	2.0		4lb blind at 4mm
	200 > 320g/m sq	1.7	2.0	2.0	1.5		
	320 > 485g/m sq	1.9	2.0	2.0	1.5		
40°	up to 200g/m sq	5.0	5.0	5.0	5.0	5.0	9lb blind at 6mm
	200 > 320g/m sq	3.75	3.75	3.75	3.75	3.75	
	320 > 485g/m sq	5.0	5.0	5.0	3.55	2.7	

## LITHIUM 1100 SERIES

PARAMETERS		FEATURES	
Rated Torque	1.1Nm	Min Blind Width	455 or 460 with Open Cassette
Rated RPM	25rpm		
Motor Diameter	25mm	Weight Capacity	3kgs (2.5m x 2.7m)*
Rated Voltage	DC7V		
Rated Power	2W		
Rated Current	0.8A	Power Source	Re-chargeable (plug-in charger or solar panel)
IP Class	IP40		
Inbuilt Receiver	No		

\*based on using Carnival fabric

Your Louvolite Lithium Motorised Roller System Distributor:



www.louvolitecommercial.com

CI/SIB 1976 reference by SIB Agency			
(76.7)	X		

S250102-40-1100 07.19