

LOUVOLITE
OneTouch[®]
ADVANCED LIGHT CONTROL



*Remote control
operation*



*App control
in or out of
the home*



*Voice activation
in the home*

TRADE GUIDE

MOTORIZED window shading

 LOUVOLITE

BLIND CONTROL FROM *anywhere in the world*

WITH LOUVOLITE ONE TOUCH® MOTORISATION

roller | vision® | roman | pleated | cellular
perfect fit® | vertical | visage® | allusion®

The way we use our homes is changing and because of that we have developed our One Touch® family so your customers can do more living. Simple, convenient and easy to use, Louvolite One Touch® makes luxury affordable with motorisation accessible to all.

An innovative range of battery operated and mains powered blinds your customer can operate multiple blinds with remote control, voice activation with Amazon Alexa and Google Home or control them while away on holiday with our app!

Our fantastic timer remote and app allows your customer to pre-set their blinds for convenience or added home security when they're out.

The rechargeable battery powered solutions remove the need for mains wiring, making it easy to install and without disruption to the home's decoration.

Louvolite One Touch® is a popular choice for the multiple windows in conservatories, shading large bi-fold doors or just for those that want easy blind operation on the go or from the comfort of the sofa.

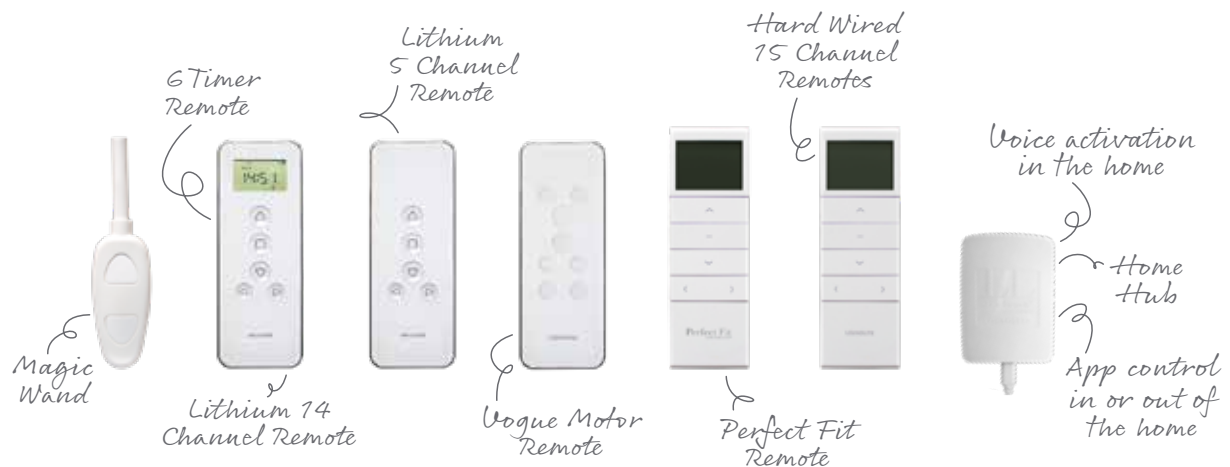



motorised
PERFECT.FIT[®]
vision[®]

Siena Charcoal, Perfect Fit[®] Motorised Vision



on the go
WITH THE
app

KEY BENEFITS

- Innovative yet affordable contemporary technology for the modern home and office.
- Child safe by design.
- Simple, convenient and easy to use.
- Operation can be with a unique wand that hangs neatly next to the blind, with remote or voice control within the home, or with the app from anywhere.
- Control multiple blinds individually or all together.
- Improved home security using the timer remote or app to control the blinds when out or away.
- Straightforward assembly enables blinds to be made and installed quickly.
- Mains powered system also available for larger blinds.

BE ON THE GO WITH the app and home hub

The Louvolite Home Hub connects to WiFi so that motorised One Touch® window blinds can be operated straight from a smart device.

Your customer just downloads the free and easy to install app, pairs their blinds to operate them separately or together from anywhere on their phone!

The hub and app works with existing Louvolite One Touch® blinds too.

It's excellent for privacy and security with the ability to open or close the blinds when they're out at work or away on holiday.

Installing the home hub makes life easier by offering the ability to control all their window blinds in a number of different ways. They can be operated by remote control, using voice control with **Amazon Alexa** or **Google Home** or via the app on their smart device whether they're home or on the go.

- The Louvolite Home Hub connects via WiFi and operates the One Touch® Lithium 1100 Series and A/C 1500 and 6000 Series motors.
- Use voice control to open or close the blinds with Amazon Alexa, Dot and Echo and Google Home.
- Improves home security with the ability to open or close the blinds when at home, out or away on holiday.
- Free, easy to use app available for IOS and Android.
- Use smart phones or tablets to view the rooms in the home and control the blinds within them.
- Control up to 15 blinds per room, individually or all together.
- Child safe by design.

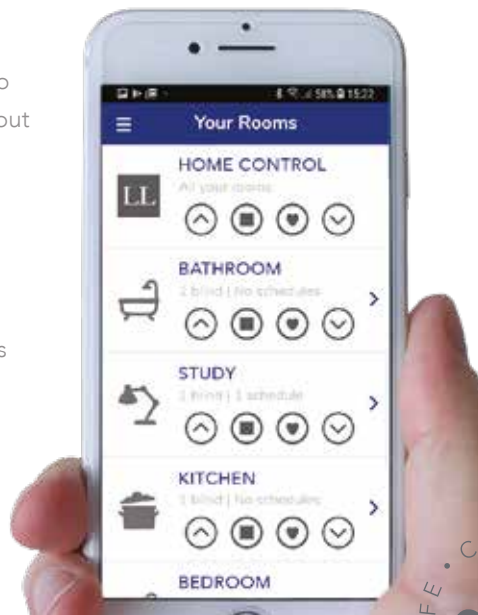

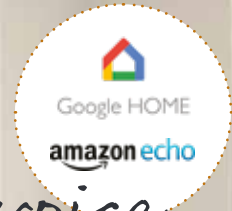

use voice
ACTIVATION



pre-set
YOUR BLINDS



blind control
FROM YOUR PHONE



great for
HOLIDAY TIME



lowvolite one touch™ AND WALK AWAY

MAGIC WAND BATTERY POWERED 300 & 700 SERIES

A cost effective motorised solution for operating a singular blind quietly and conveniently at the touch of a button. The unique and stylish wand hangs neatly at the edge of the blind.

The 300 series is for blinds up to 1.6m wide and 1.6m drop and is right hand reverse rolled operated.

The 700 series can be right or left hand reverse rolled operated. A highly effective motorised solution for the home it can lift larger blinds and heavier fabrics of up to 2.2m wide or 2.4m drop.

- Easy to use and operates a singular blind.
- Hangs neatly next to the blind.
- Ideal for kitchens, bathrooms and children's bedrooms.
- Uses standard AA batteries - no installation wiring required!
- Limits to stop blind at a highest and lowest point.
- Child safe by design.
- Warning sound when battery charge is low.
- Available as Roller, Pleated and Vision® blinds.

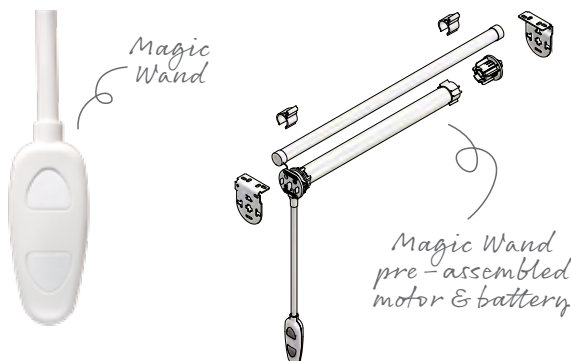

PERFORMANCE PARAMETERS	300 SERIES	700 SERIES
Rated Torque	0.3Nm	0.7Nm
Rated RPM	34rpm	34rpm
Motor Diameter	25mm	25mm
Rated Voltage	DC12V	DC12V
Rated Power	4.2W	9.6W
Rated Current	0.35A	0.8A
IP Class	IP40	IP40
Inbuilt Receiver	No	No
Minimum Blind Width *with open cassette	360mm/*460mm	360mm/*460mm
Weight Capacity *using Carnival fabric	1kg *approx. 1.6m x 1.6m	2.4kgs *approx. 2.2m x 2.4m



Wonderland Pastel, Motorised Perfect Fit Roller

LITHIUM PERFECT FIT 15MM MOTOR

A convenient and no fuss choice for the multiple windows in conservatories as well as through out the home. Operate up to 15 blinds from anywhere in the room using remote, voice control or the app!

- Remote control - can operate up to 15 blinds separately or simultaneously.
- Can be used with the app or voice activation.
- Rechargeable battery - no installation wiring required!
- Child safe by design.
- Flashes red when battery is low.
- Available as Roller, Pleated, Vision® and Cellular fabrics

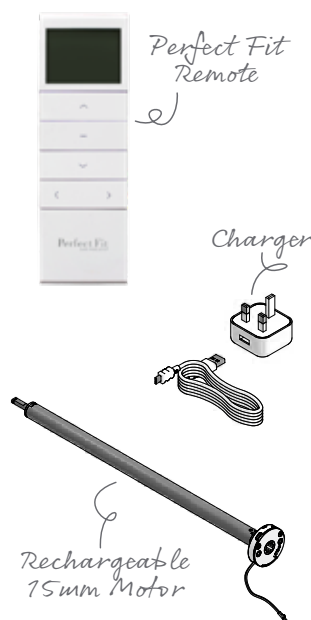

PERFORMANCE PARAMETERS	PERFECT FIT
Rated Torque	0.3Nm
Rated RPM	30rpm
Motor Diameter	15mm
Rated Voltage	DC5V
Rated Power	5W
Rated Current	0.6A
IP Class	IP20
Inbuilt Receiver	No
Minimum Blind Width	400mm
Weight Capacity	1kg

LITHIUM RECHARGEABLE 1100 SERIES

For blinds up to 2.5m wide and 2.7m drop, our popular 1100 series is economically maintained with its rechargeable battery.

Control multiple blinds separately or simultaneously from anywhere in the room with the sleek remote. The convenient timer remote can pre-set up to 6 blinds to raise or lower at chosen times, or use the app from your smart device to control the blinds while you're out!

A sustainable charging option, the solar panel gathers daylight and trickle charges the motor.

- Stylish remote control - can operate up to 14 blinds separately or simultaneously (remote dependant).
- Rechargeable battery - no installation wiring required!
- 4m charger cable or opt for the solar panel.
- Limits to stop blind at a highest, mid and lowest point.
- Timer remote - pre-set blinds to raise or lower at specific times.
- Child safe by design.
- Lithium motor pairs with the Louvolite home hub for app control in or out of the home from a smart device and voice activation with Amazon Alexa and Google Home within the home.
- Available as Roller, Roman, Pleated, Vision®, Visage®, Cellular and Perfect Fit® blinds.

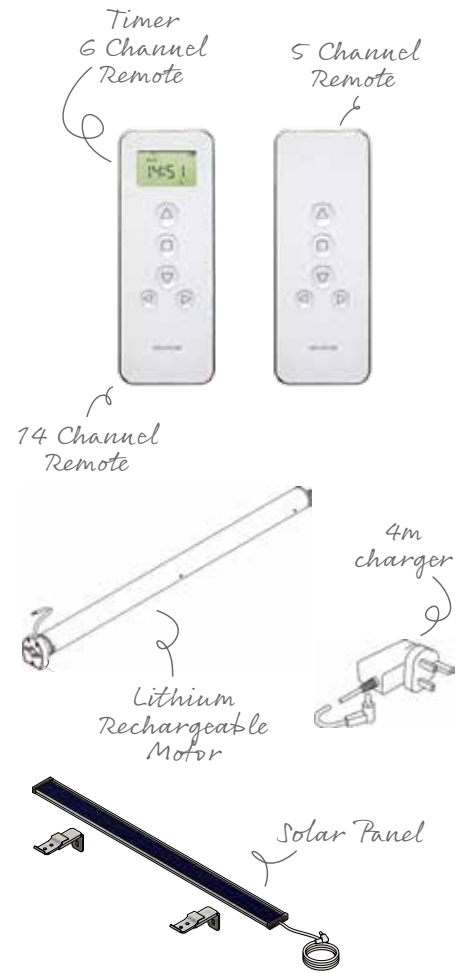

PERFORMANCE PARAMETERS	1100 SERIES
Rated Torque	1.1Nm
Rated RPM	25rpm
Motor Diameter	25mm
Rated Voltage	DC7V
Rated Power	2W
Rated Current	0.8A
IP Class	IP40
Inbuilt Receiver	No
Minimum Blind Width *with open cassette	455mm/*460mm
Weight Capacity *using Carnival fabric	3kg *approx. 2.5m x 2.7m



Parchment SPC® Bamboo, Motorised Pleated

stylish
CONVENIENCE



one touch
CONTROL

Cherry Blossom Geisha, Motorised Roman



hands free
ASSISTANCE



“open blinds”
 GOOGLE HOME
voice control



Inky Charcoal, Motorised Vertical



Vista Snow, Motorised Allusion®

SLIMLINE® VOGUE MOTOR

Operate vertical and Allusion® blinds from anywhere in the room! Rotate the louvres 45° or 90° clockwise or anticlockwise until fully closed using the stylish remote or with the home hub using the app or voice control*.

Fully draw open or closed with the wand hanging at the edge of the blind.

- Stylish remote control - can operate up to 5 blinds separately or simultaneously.
- Can be used with the app or voice activation*.
- Rechargeable battery - no installation wiring required!
- Motorised 0°, 45°, 90°, 135° and 180° rotation.
- Child safe by design.
- Flashes red when battery charge is low.
- Available for Vertical and Allusion® blinds.

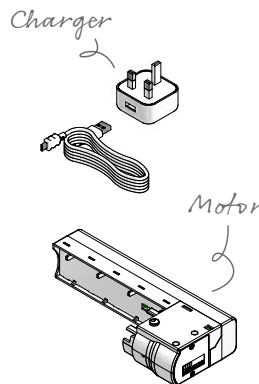

PERFORMANCE PARAMETERS	VERTICAL
Rated Torque	0.1Nm
Rated RPM	42rpm
Motor Diameter	12mm
Rated Voltage	DC4.2V
Rated Power	0.67W
Rated Current	160mA
IP Class	IP20
Inbuilt Receiver	Yes
Minimum Blind Width	200mm

*Vogue® motor only compatible with Google Home.

MAINS POWERED A/C MOTOR 1500 & 6000 SERIES

The a/c mains motorised solutions are ideal for large, modern windows and commercial installations.

The 1500 series works with the 35, 40 and 45mm tubes and can lift blinds up to 3m wide or 3.5m drop.

The 6000 series uses the 55mm tube and is a highly effective motorised solution that can lift larger blinds and heavier fabrics of up to 4m wide or 6m drop.

- An innovative 240V mains powered A/C motor system.
- Designed to lift bigger blinds or heavy fabrics, perfect for large, modern windows or commercial installations.
- Remote operation - up to 15 blinds separately or simultaneously.
- Limits to stop blind at a highest, mid and lowest point.
- Sound suppression available for operating larger blinds.
- Child safe by design.
- Can be operated with the app from a smart device or voice control with Amazon Alexa and Google Home.
- Available as Roller, Roman, Pleated, Vision®, Visage® and Cellular blinds.



Perspective Desert Sand, Motorised Roller

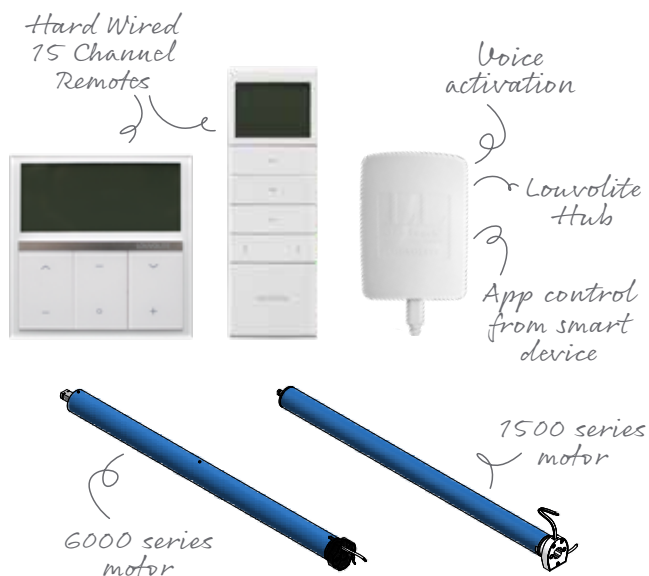

PERFORMANCE PARAMETERS	1500 SERIES	6000 SERIES
Rated Torque	1.5Nm	6Nm
Rated RPM	32rpm	28rpm
Motor Diameter	25mm	35mm
Rated Voltage	DC110V/230V	DC230V
Rated Power	15.3W	144W
Rated Current	0.13A	0.63A
IP Class	IP44	IP44
Cable	2 Core	3 Core
Inbuilt Receiver	Yes	Yes
Minimum Blind Width	500mm	650mm
Weight Capacity <small>*using Carnival fabric</small>	5kgs <small>*approx. 3m x 3.5m</small>	12kgs <small>*approx. 4m x 6m</small>



Google HOME

amazon echo

simple living
WITH VOICE ACTIVATION

Willow Brazen Yellow, Lithium Motorised Roller

 LOUVOLITE